



Separator
Core machine



Dust collector

Specifications

Effective cutting size	350*550MM
Cutting capacity	Ability to cut straight lines, arcs, circles, L-shaped, U-shaped, stamp-hole models, and V-slot models Required items
Working area (machinable stroke)	V groove, stamp hole, bridge and circle, etc.
Cutting PCB thickness range	0.3-3mm
Repeat positioning accuracy	± 0.01mm
Tool monitoring	Automatic tool sinking, tool breaking and sliding tool detection
Cutting speed	5 ~ 100mm/s adjustable
Spindle speed	Max 60000 rev/min
Work table	Daul Table
Applicable milling cutter size	0.8 ~ 3.0MM
Computers and Operating Systems	Industrial computer, Windows 7 or above
X, Y1, Y2, Z axis	Panasonic A6 series servo drive
Power Separator/Dust collector	AC220V 50/60HZ 1 HP/AC380V 3 HP
Separator Size/Weight	1180mm*1180mm*1350mm/800kg
Dust collector size/Weight	665mm*635mm*1610mm/155KG
Dust collection method	bottom dust collection/top dust collection (optional)

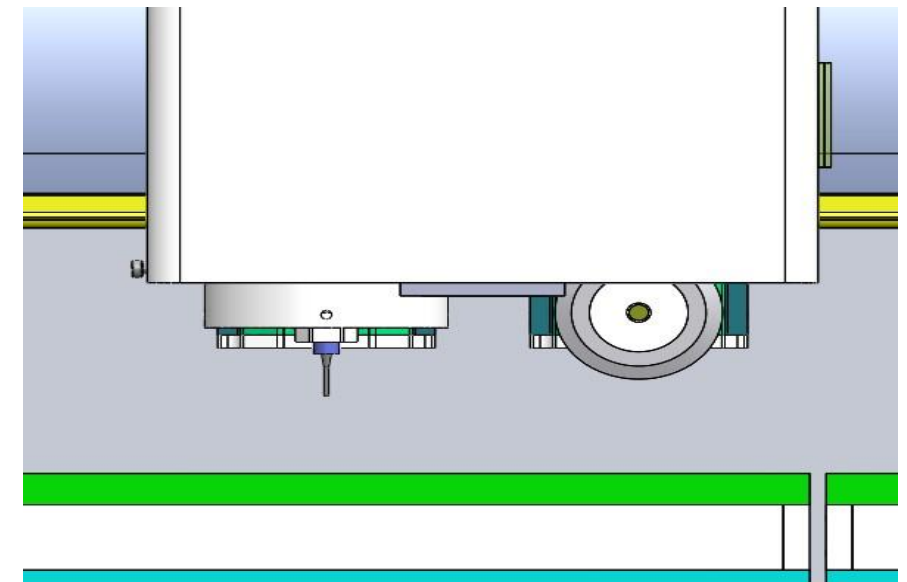
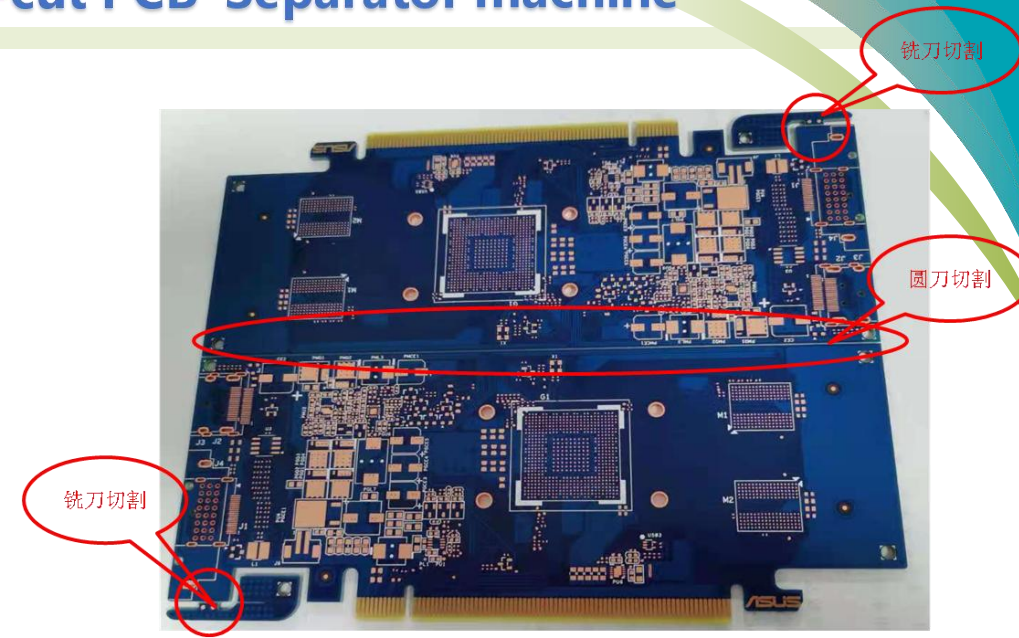

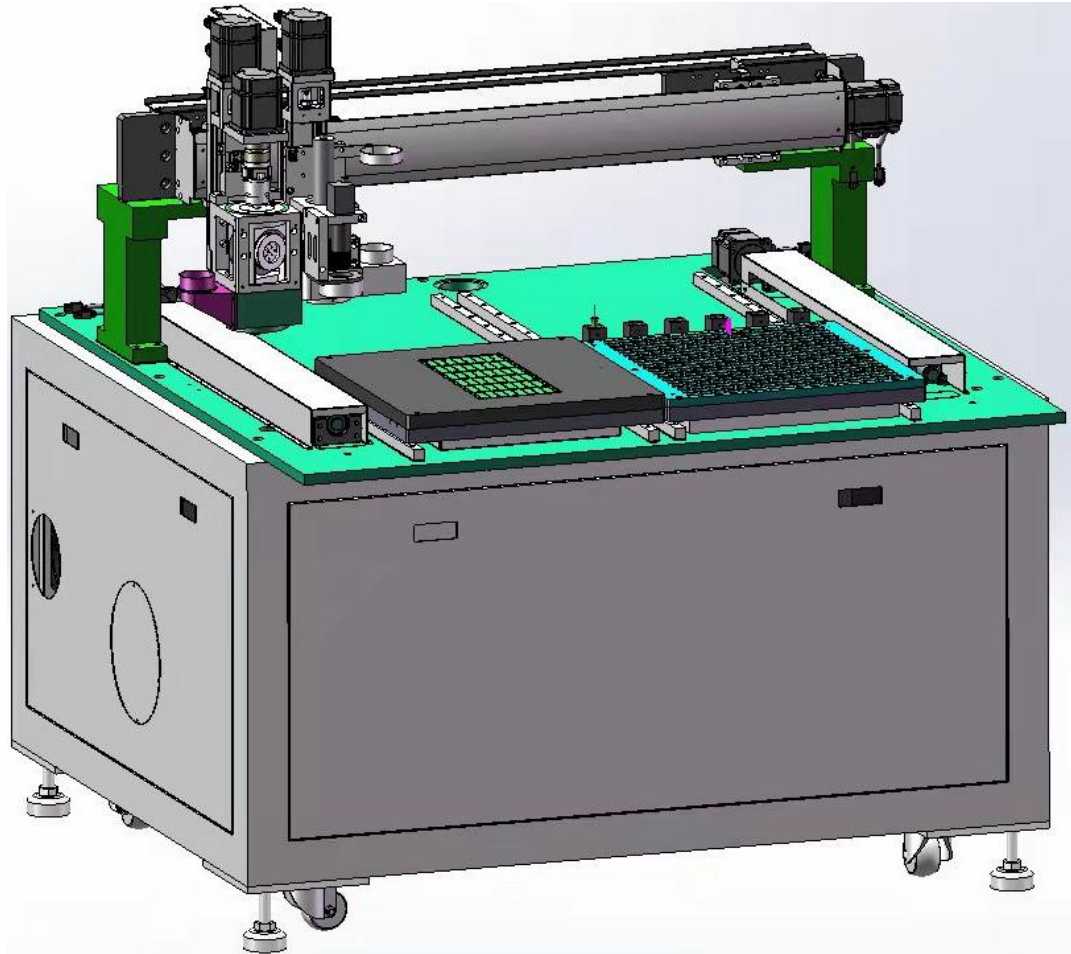

Dual-table uninterrupted working, with safety grating

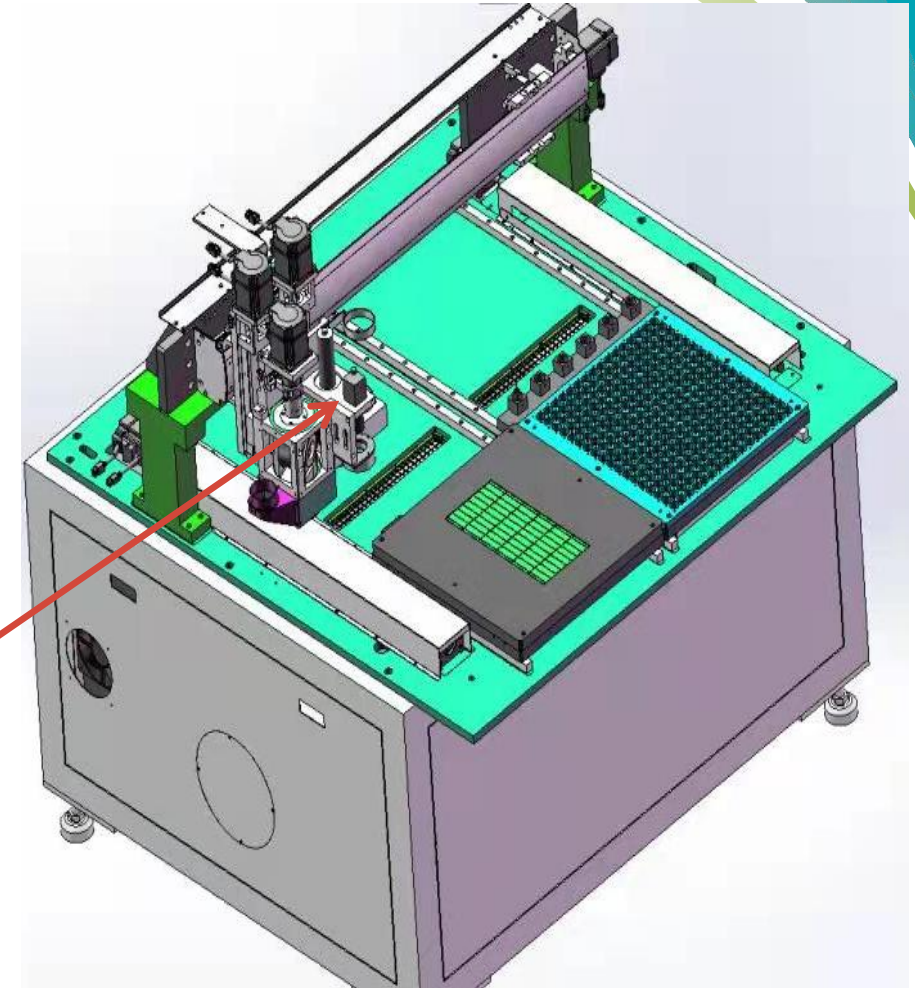
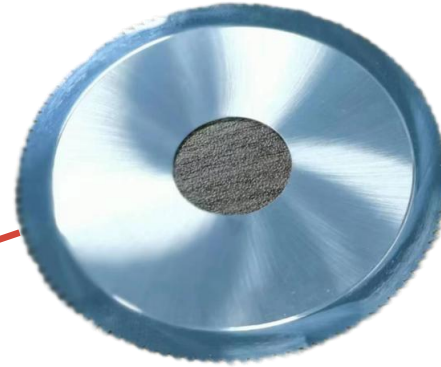
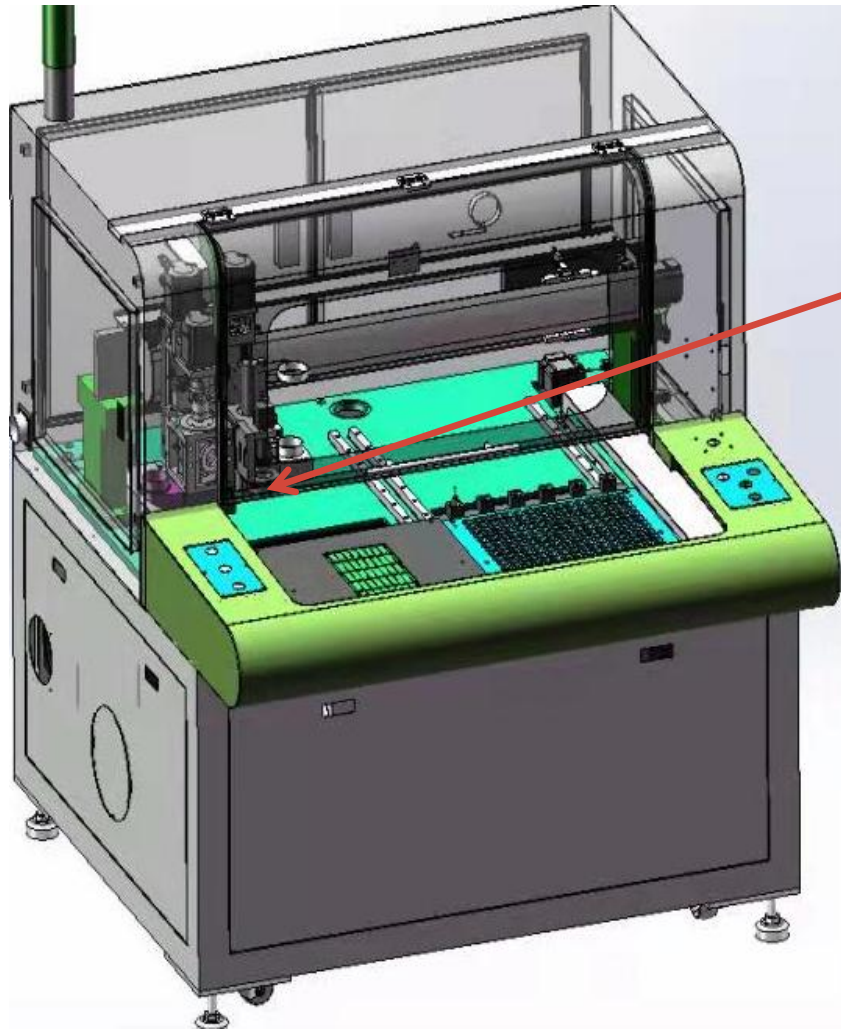

Circular Blade for V Groove

Milling Cutter for Stamp → Hole

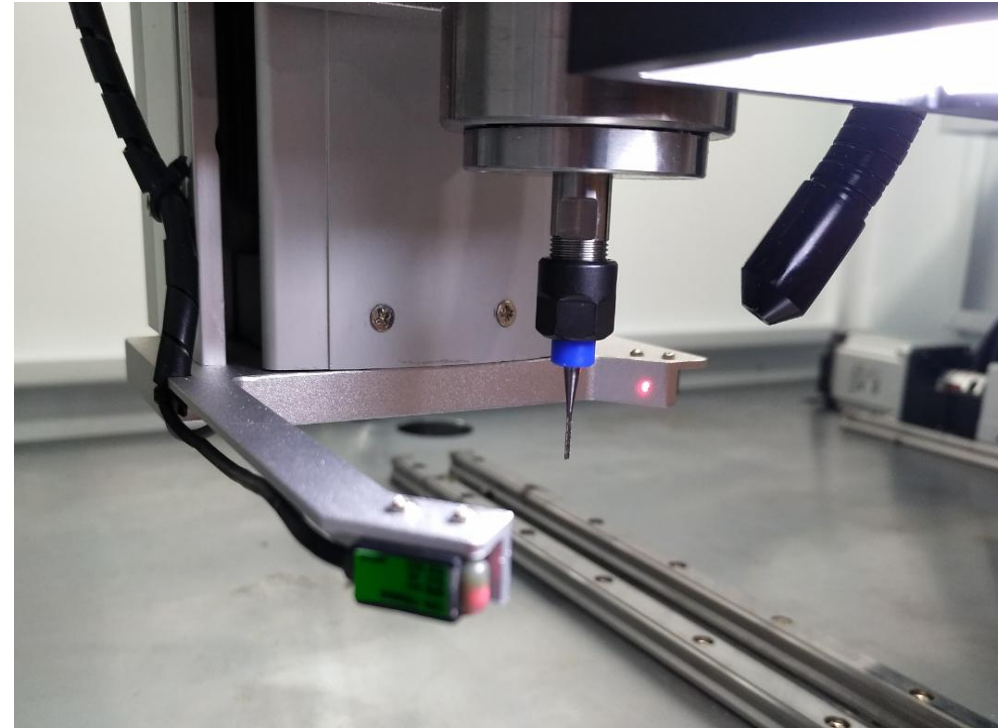
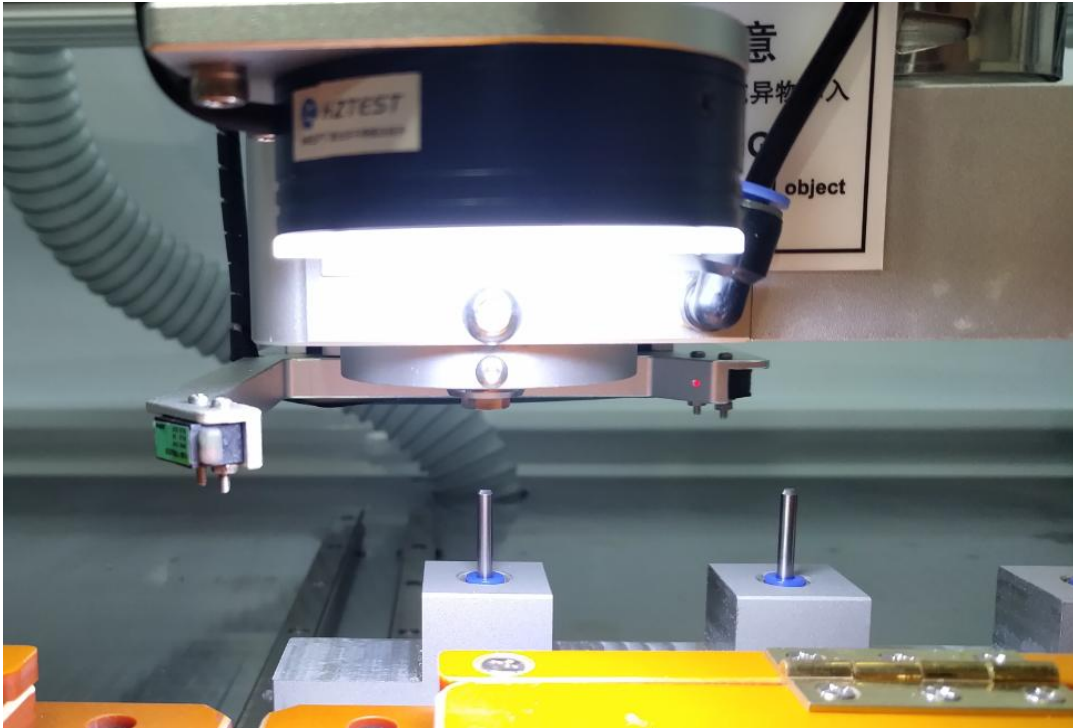

Automatic cutter changing over and breaking detection

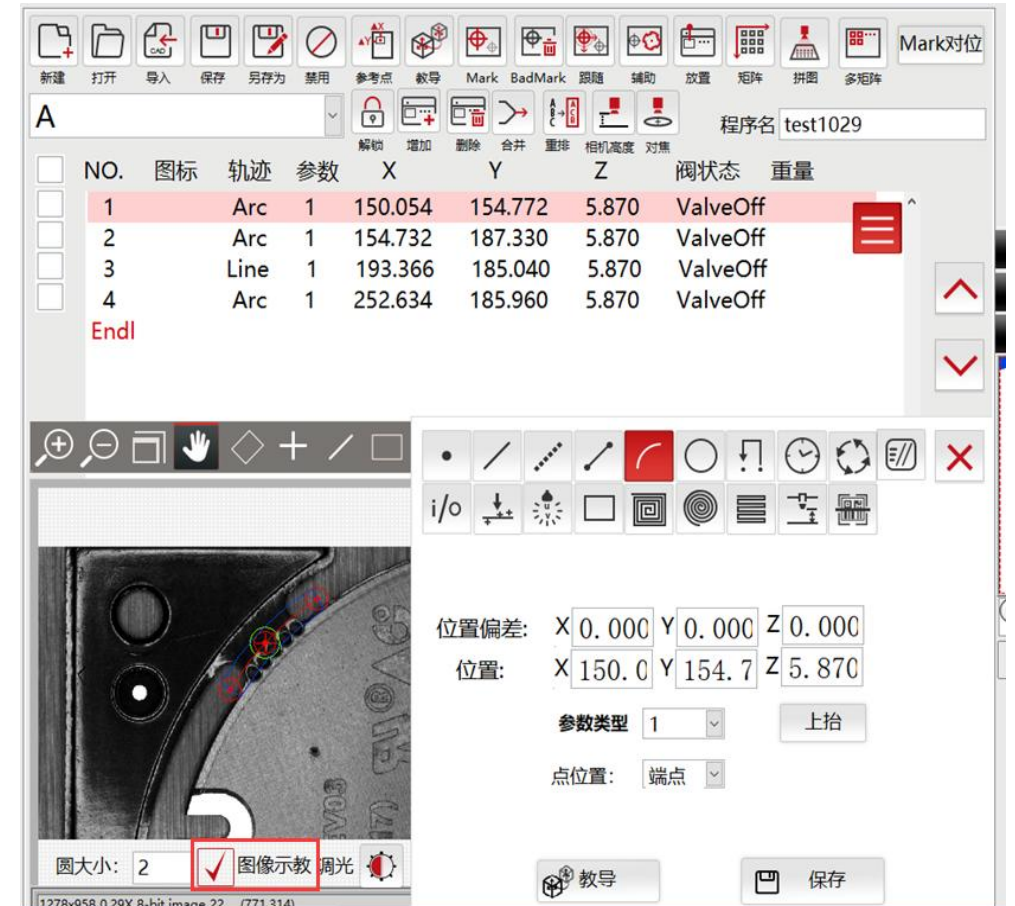
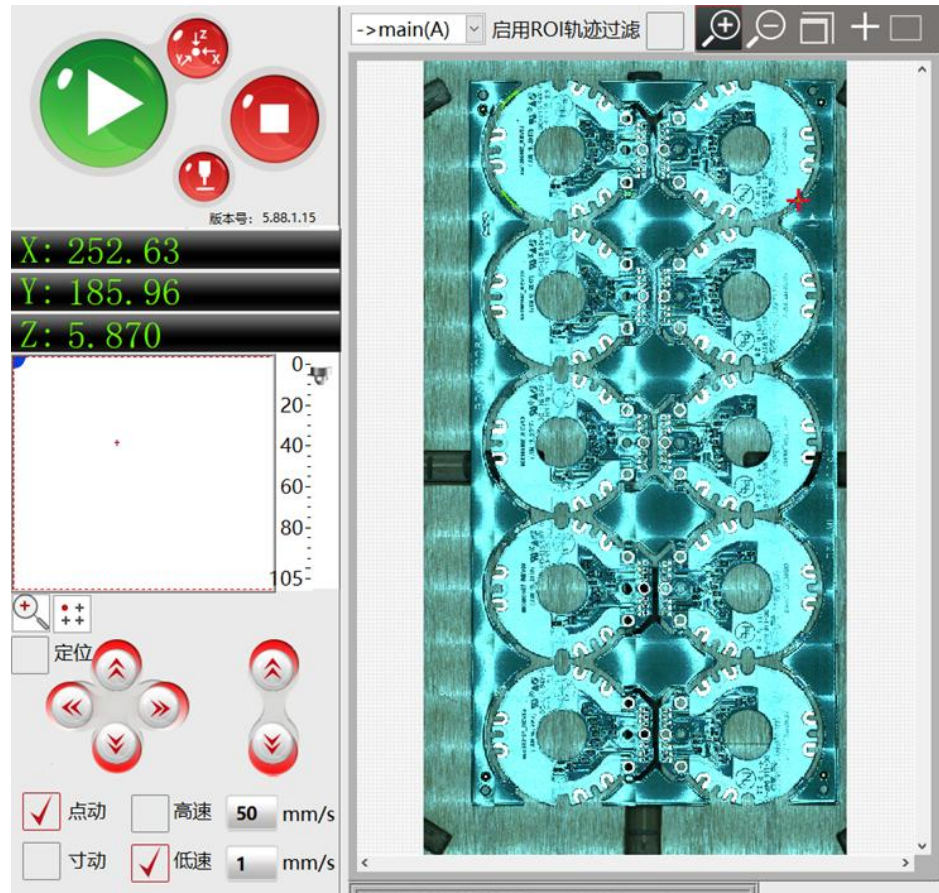

Accurate and fast positioning of the MARK point and cutting line

Faster and smarter programming

Best After-sales service

- **Free Installation/ Training**
 - **1 day lead-time (spare parts)**
 - **5 days customized design**
 - **7x24 Worldwide Support**
- 

Welcome Inquiry

Please visit

www.smthelp.com

Find us more

<https://www.facebook.com/autoinsertion>

Know more our team

<https://www.linkedin.com/company/smtmachine>

Welcome to our factory in Shenzhen China

See more our machine please Google

[Auto Insertion](#)

Youtube

<https://www.youtube.com/c/Smthelping>

Looking forward to your email

info@smthelp.com